



SUPPLEMENTAL BID BULLETIN RFQ No. 2026-0039 Notice Reference No. 21563

Supplemental Bid Bulletin No. 2026-010 is issued to update the schedule of activities for the RFQ No. 2026-0039 “**INSTALLATION OF ADDITIONAL 37.5KVA TRANSFORMER AND IMPROVEMENT OF ROOM FOR BUKID HUB AT ENGINEERING BUILDING AT MINSU MAIN CAMPUS**” relative to the postponement/extension of the Closing, Submission and Opening of quotations. The following schedule must be observed:

REFERENCE	CLARIFICATION
<p>Closing Date & Time: April 20, 2026; 9:00 AM</p> <p>Deadline for Submission of Quotation: April 20, 2026; 9:00 AM</p> <p>Opening of Quotations: April 20, 2026; 10:00 AM</p>	<p>Closing Date & Time: May 7, 2026; 9:00 AM</p> <p>Deadline for Submission of Quotation: May 7, 2026; 9:00 AM</p> <p>Opening of Quotations: May 7, 2026; 10:00 PM</p>

Issued on 27th day of April 2026 at Victoria, Oriental Mindoro.

For guidance and information of all concerned.

CIEDELLE P. SALAZAR, Ph.D.
BAC Chairperson





REQUEST FOR QUOTATION

Mindoro State University (MinSU) Main Campus through Bids and Awards Committee will undertake **Small Value Procurement** pursuant to the provisions of R.A. 12009, to wit;

Name of Project	INSTALLATION OF ADDITIONAL 37.5KVA TRANSFORMER AND IMPROVEMENT OF ROOM FOR BUKID HUB AT ENGINEERING BUILDING AT MINSU MAIN CAMPUS
Solicitation	RFQ 2026-0039
Place of Delivery	MINSU MAIN CAMPUS
Brief Description	37.5KVA TRANSFORMER AND IMPROVEMENT OF ROOM FOR BUKID HUB AT ENGINEERING BUILDING AT MINSU MAIN CAMPUS
Quantity	One (1) Lot
Approved Budget for the Contract (ABC)	Php. 500,000.00
Date of Delivery	38 days upon conformed of Notice to proceed

Please quote your **lowest price** on the attached bid form and submit personally/through email your **SEALED QUOTATION not later than on 9:00** 07 MAY 2026 **at the Bids and Awards Committee (BAC) Office, Mindoro State University -Main Campus, Alcate, Victoria, Oriental Mindoro.**

Received by:

Name and Signature: _____

Company: _____

Date: _____

CIEDELLE PIOL-SALAZAR, Ph.D.
BAC Chairperson

Terms and Conditions:

1. All entries must be **LEGIBLE**.
2. Delivery Period within ___ calendar days.
3. Warranty shall be for a period of six (6) months for supplies and materials, one (1) year for Equipment, from date of acceptance by the procuring entity.
4. Price validity shall be a period of 30 calendar days.
5. PhilGEPS Registration Certificate shall be attached upon submission of the Quotation.
6. Bidders shall submit Original Brochures showing certification of the product being offered (Required; if applicable).
7. Mode of delivery: [] Pick-up (Schedule) [] Door to Door Delivery



Webometrics
OF UNIVERSITIES



BID FORM

item/s and Specification/s (minimum)	Unit	Qty.	Brand / Specification	Unit Price (VAT inclusive)	Total Amount (VAT inclusive)	Compliance with Technical Specifications (please check)	
						YES	NO
101 - Mobilization	lot	1					
102 - High Voltage Works	lot	1				()	()
103 - Electrical Works	lot	1				()	()
104 - Plumbing Works	lot	1				()	()
nothing follows							
TOTAL							

General Conditions

1. Quotations and other requirements stated below shall be submitted to the **Bids and Awards Committee (BAC) Office, Mindoro State University -Main Campus, Alcate, Victoria, Oriental Mindoro, Philippines** on the date and time stated in this RFP.

2. Supplier shall submit the following requirements:

- () Duly signed original copy of Request for Quotation (RFQ). Prices shall be quoted in
- () Notarized Omnibus Sworn Statement (if above 200k as lot basis)
- () PhilGEPS Platinum Certificate of Registration (**only if Platinum Certificate**) (Valid, updated and Active and no expired document listed on the last page) with CTC
- () Brochure (if Goods and Equipment) (Updated & Original or CTC)
- () PCAB License(if infrastructure)(Updated & Original or CTC)
- () BIR certificate of Registration (BIR 2303)(Updated & Original or CTC)
- Please submit if the PhilGEPS Registration is RED**
- () PhilGEPS proof of Red Registration (Updated & Original or CTC)
- () DTI/SEC/CDA Registration (Updated & Original or CTC)
- () Business/ Mayor's Permit (Updated & Original or CTC)
- () Tax Clearance/ Tax Compliance Verification Cert (Updated & Original or CTC)
- () Latest Income / Business Tax Return (Updated & Original or CTC)





() Audited Financial Statement (Updated & Original or CTC)

Note: Please ensure that all non-original documents, including those submitted via email or in person, are duly certified as true copies (CTC) and bear the name and signature of the authorized representative. Failure to comply with this requirement may result in disqualification.

Price validity shall be 30 calendar days from the deadline of submission of quotation.

Ocular Inspection

The supplier and its premises **may be subjected to ocular inspection or verification** by the End-User and/or the BAC Technical Working Group (TWG), **if deemed necessary to confirm compliance with technical specifications prior to award.**

Award

The contract shall be awarded to the supplier who:

1. Submitted the **Lowest Calculated and Responsive Bid (LCRB)**; and
2. Successfully **passed verification of compliance with eligibility, technical requirements, and, if applicable, ocular inspection or post-qualification** performed by the TWG.

Award is **subject to the approval of the Head of the Procuring Entity** and is **conditional upon compliance with all requirements** under RA 12009, the GPPB guidelines, and the RFQ. If the supplier with the LCRB **fails verification or inspection**, the BAC may consider the **next lowest responsive bid.**

Evaluation of Quotations

Quotations shall be compared and evaluated based on:

1. Completeness of Submission of all required documents
2. Compliance with Item & Description Requirements
3. Reasonableness and competitiveness of the quoted price, evaluated based on the **LCRB/HRRB/MEARB/MARB** in relation to the Approved Budget for the Contract (ABC).

Instructions

1. Supplier shall be responsible for the source(s) of its goods/services/equipment, and which shall be in accordance with the schedule and specifications of the RFQ and contract. Failure of the supplier to comply with this provision shall be ground for cancellation of the award or purchase order issued to the supplier.
2. Supplier that accepted an award, purchase order, or contract but failed to deliver the required goods/services/equipment within the time called for in the award, purchase order, and contract shall be disqualified from participating in MinSU or any of MinSU campuses future procurement activities. This is without prejudice to the imposition of other sanctions prescribed under R.A. 9184 and its IRR-A against the supplier.
3. The supplier is responsible for **all duties, excise, taxes, and other government charges.**
4. All transactions are subject to withholding of creditable government taxes in accordance with the revenue regulation(s) of the Bureau of Internal Revenue



Document transmission service

The supplier shall shoulder the courier expenses for the delivery of documents such as the **Notice of Award (NOA), Purchase Order (PO), Contract Agreement (CA), Notice to Proceed (NTP)** and other related documents pertaining to the supplier.

Liquidation Damages

A penalty of one-tenth of one percent (0.001) of the total contract price per calendar day shall be imposed for any delay in the delivery of goods, services, or equipment. The total liquidated damages shall not exceed 10% of the total contract price. Exceeding this threshold shall constitute a ground for termination of the contract by the BAC.

Warranty

The supplier warrants that all goods, services, or equipment conform to acceptable industry standards and the specifications stated in the RFQ and contract. Any defect or non-conformance discovered during the warranty period shall be remedied by the supplier at no additional cost.

Payment

Payment shall be made only upon a certification by the Head of the Procuring Entity to the effect that the GOODS have been rendered, delivered or installed in accordance with the terms of this Contract and have been duly inspected and accepted by the

_____.

After having carefully read and accepted your Terms and Conditions. I/We quote you on the item at prices noted above.

Printed Name of authorized representative/Signature _____

Position: _____

Name of Company _____

Address: _____ Email Address: _____

Fax No. _____ Tel No.: _____ Cellphone No. _____

Date: _____

LBP Account No. of Establishment: _____

Name of Payee: _____

Tax Identification Number: _____

Copy of PhilGEPS Registration No.: _____

BIR Registration: VAT Non-VAT

Canvassed by:

MARK CHRISTIAN M. MAGNAYE
Canvasser

Contact Number: 0945-664-3003
Email Address: bac.office@mins.edu.ph



Webometrics
OF UNIVERSITIES

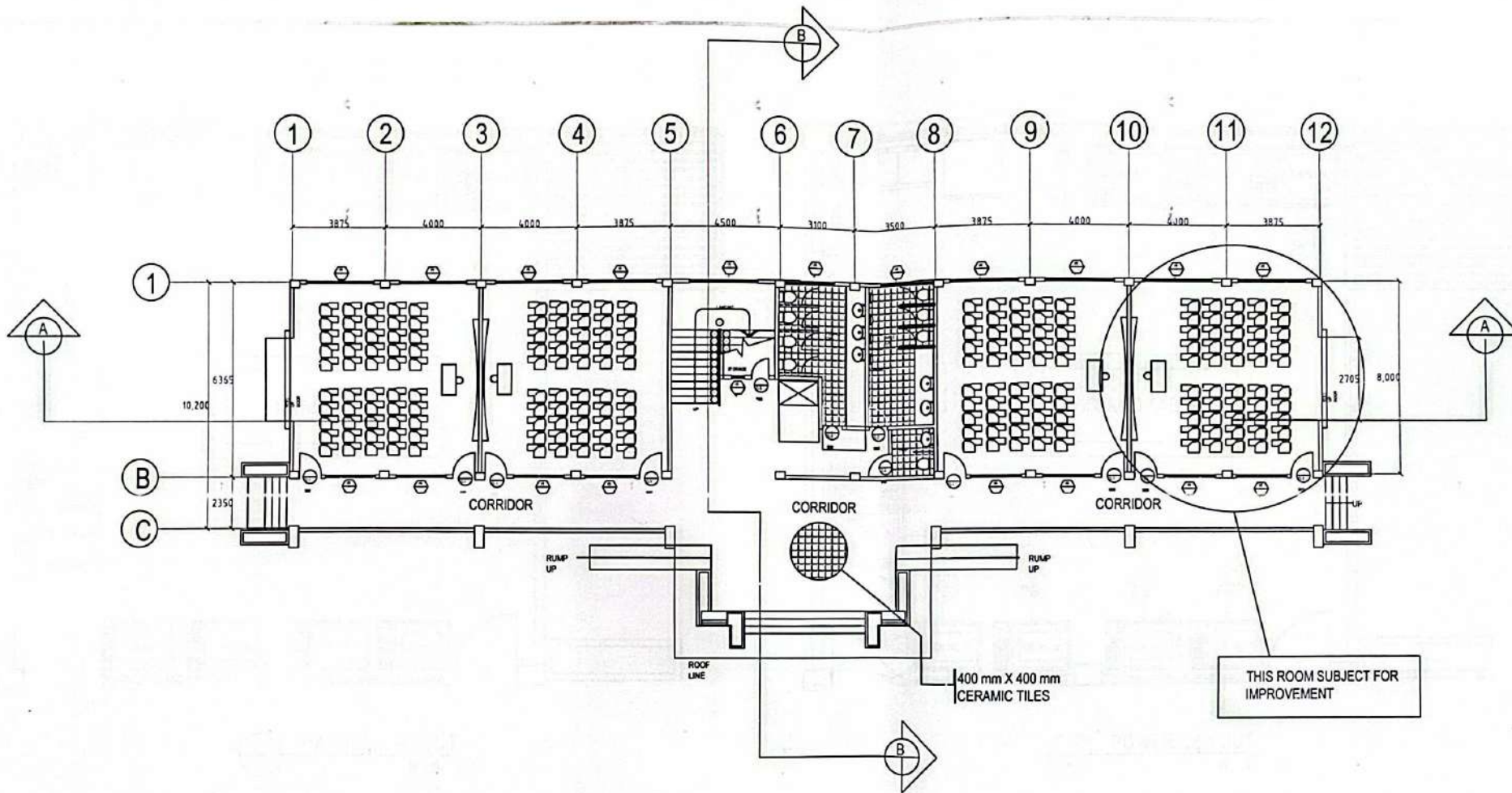

GROUND FLOOR PLAN
N.T.S.



MINDORO STATE UNIVERSITY

MAIN CAMPUS

R.A. 9284, Art 3, Sec 20
Drawings and Specifications duly signed, stamped or sealed, as instruments of service, are the intellectual properties and documents of the architect, whether the subject for which they are made is executed or not. It shall be unlawful for any person, without the consent of the architect, or author of said documents for use in the repetition of and for other project or buildings, whether executed partly or in whole

Project Title:
INSTALLATION OF ADDITIONAL 37.5 KVA TRANSFORMER AND IMPROVEMENT OF ROOM FOR BUKID HUGA AT ENGINEERING BUILDING AT MINSU MAIN CAMPUS

Location:
BROG ALGATE, VICTORIA, ORIENTAL MINDORO

Prepared by:
Johny M. Berguera
ENGR. MARCELO BERGUERA
ADMINISTRATIVE OFFICER IV

Checked and Approved by:
Mark Lester Magpantay
ENGR. MARK LESTER MAGPANTAY
PROJECT DEVELOPMENT OFFICER III

Validated by:
Arvin P. Tolentino
ENGR. ARVIN P. TOLENTINO
DIRECTOR FOR AUXILIARY AND GENERAL SERVICES

Recommending Approval:
Rovertin P. Roxas
ROVERTIN P. ROXAS
OIC - VP FOR ADMIN & FINANCE

Approved by:
Enya Marie D. Apostol
ENYA MARIE D. APOSTOL, Ph.D.
UNIVERSITY PRESIDENT

Sheet No.
A1

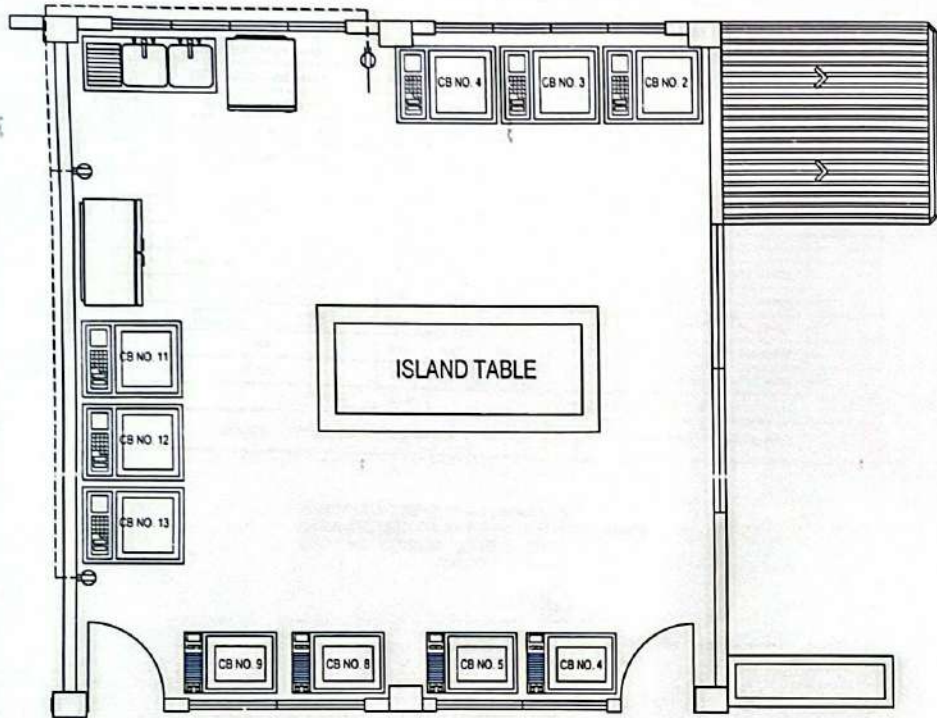

○ MACHINE LAYOUT
N.T.S.

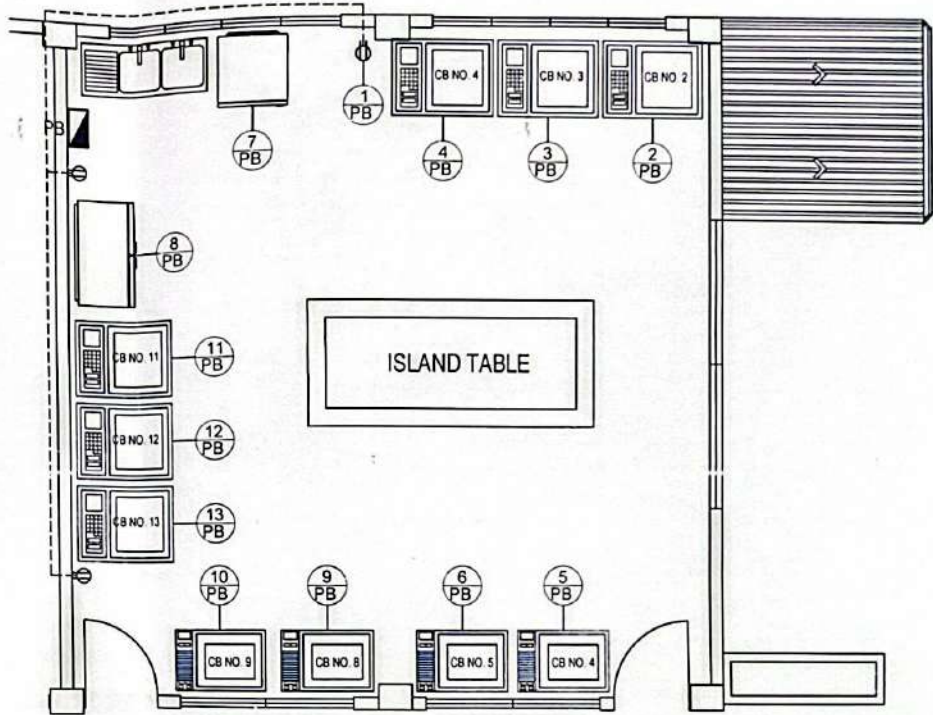

○ POWER LAYOUT
N.T.S.



MINDORO STATE UNIVERSITY
Main Campus

R.A. 9294, Art 3, Sec 20
Drawings and Specifications duly signed, stamped or sealed, as instruments of service, are the intellectual properties and documents of the architect, whether the object for which they are made is executed or not, it shall be unlawful for any person, without the consent of the architect, or author of said documents for use in the repetition of and for other project or buildings, whether executed partly or in whole.

Project Title: INSTALLATION OF ADDITIONAL 37.5 KVA TRANSFORMER AND IMPROVEMENT OF ROOM FOR BUKID HUB AT ENGINEERING BUILDING AT MINSU MAIN CAMPUS
Location: BRGY. ALCATE, VICTORIA, ORIENTAL MINDORO

Prepared by: ENGR. MICHELLE D. BERGUERA
ADMINISTRATIVE OFFICER IV

Checked and Approved: ENGR. MARCELO A. MANGPANTA
PROJECT DEVELOPMENT OFFICER III

Verified by: ENGR. ARVIN P. TOLENTINO
DIRECTOR FOR AUXILIARY AND GENERAL SERVICES

Recommending Approval: ROVELYN P. ROXAS
OIC - VP FOR ADMIN & FINANCE

Approved by: ENYA MAPLE D. APOSTOL, Ph.D.
UNIVERSITY PRESIDENT

A2

SCHEDULE OF LOADS AND COMPUTATIONS:

CKT NO	LOAD DESCRIPTION	VA PER CKT	VOLTS	BRANCH CKT BREAKER			SIZE OF HOMERUN (WIRES IN CONDUIT)
				AF	P	C.T	
1	CONVENIENCE OUTLET	540	230	50	2	20	2-3.5mm ² THHN IN 20mm \varnothing C PVC
2	DEHYDRATOR MACHINE	2760	230	50	2	30	2-5.5mm ² THHN IN 20mm \varnothing C PVC
3	CONTINUOUS BAND SEALER	1840	230	50	2	30	2-5.5mm ² THHN IN 20mm \varnothing C PVC
4	HEAVY DUTY BLENDER	2760	230	50	2	30	2-5.5mm ² THHN IN 20mm \varnothing C PVC
5	PLASTIC LABELING MACHINE	2760	230	50	2	30	2-5.5mm ² THHN IN 20mm \varnothing C PVC
6	PLASTIC LABELING MACHINE	2760	230	50	2	30	2-5.5mm ² THHN IN 20mm \varnothing C PVC
7	FREEZER	1840	230	50	2	30	2-5.5mm ² THHN IN 20mm \varnothing C PVC
8	REFRIGERATOR	1840	230	50	2	30	2-5.5mm ² THHN IN 20mm \varnothing C PVC
9	VACUUM PACKING MACHINE	2760	230	50	2	30	2-5.5mm ² THHN IN 20mm \varnothing C PVC
10	ESSENTIAL OIL DISTILLATION UNIT	2760	230	50	2	30	2-5.5mm ² THHN IN 20mm \varnothing C PVC
11	VERTICAL AUTOCLAVE CANNED FOOD STERILIZER MACHINE	2760	230	50	2	30	2-5.5mm ² THHN IN 20mm \varnothing C PVC
12	VERTICAL AUTOCLAVE CANNED FOOD STERILIZER MACHINE	2760	230	50	2	30	2-5.5mm ² THHN IN 20mm \varnothing C PVC
13	OVEN	3000	230	50	2	30	2-5.5mm ² THHN IN 20mm \varnothing C PVC
14	SPARE	1000	230	50	2	20	2-3.5mm ² THHN IN 20mm \varnothing C PVC
TOTAL		32140	MAIN BREAKER: 175AT, 2P, 230V				

IL @ 85% D.F. = $(\frac{32140}{230}) \cdot 0.85 = 118.78$ AMPERES USE 2 - 60mm² THHN - 1 - 8.0mm² THHN (G) IN 40mm \varnothing PVC

OVERHEAD SERVICE ENTRANCE CONNECTED TO 37.5 KVA TRANSFORMER 230V AC, 1PHASE, 2 WIRE, 60 Hz

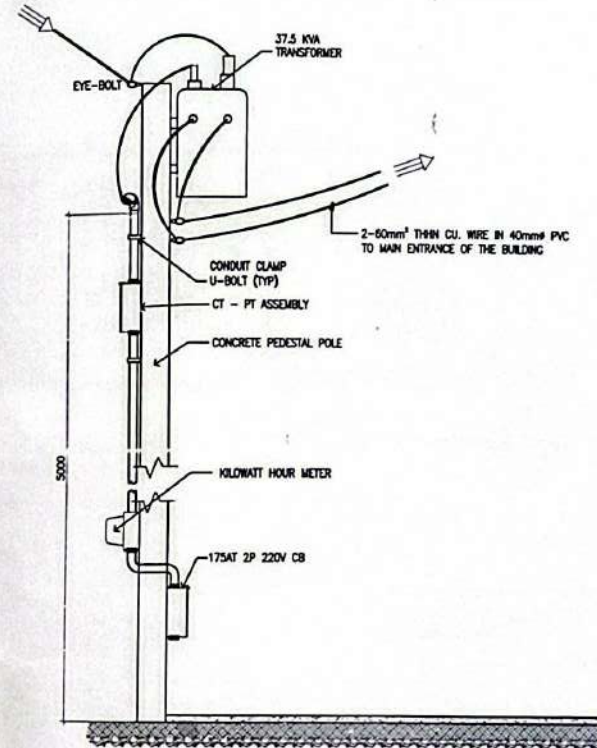
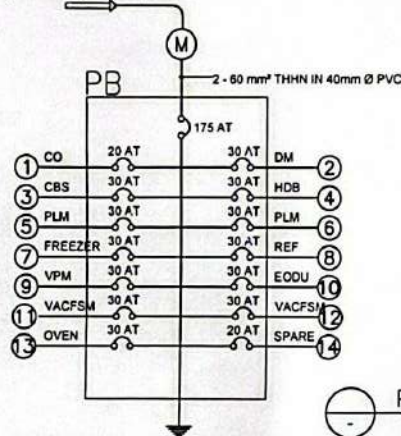

	Project Owner: MINDORO STATE UNIVERSITY	R.A. 9246, Art 3, Sec 29 Drawings and Specifications duly signed, stamped or sealed, as instruments of service, are the intellectual property and documents of the architect, neither the copy for which they are made as executed or not, it shall be unlawful for any person, without the consent of the architect, or author of said documents for use in the repetition of and for other project or buildings, whether associated party or in whole.	Project Title: INSTALLATION OF ADDITIONAL 37.5 KVA TRANSFORMER AND IMPROVEMENT OF ROOM FOR BUKID HUB AT ENGINEERING BUILDING AT MINSU MAIN CAMPUS	Prepared by: ENGR. MICHAEL BERGUERA	Checked and Reviewed by: ENGR. MARK LESTER MAGPANTAY	Written by: ENGR. RYAN TOLENTINO	Recommending Approval: ROSELYN ROXAS	Approved by: ENYA MARIE DIAPOSTOL, Ph.D.	A3
	Location: MAIN CAMPUS	License: BIRYO, ALCATÉ, VICTORIA, ORIENTAL MINDORO	Administrative Officer IV	Project Development Officer III	Director for Auxiliary and General Services	OIC - VP FOR ADMIN & FINANCE	University President		